



2.4GHz Wireless Audio/Video Kit
Universal IR Remote Control Extension
With 8 Coded Channels

User Manual

W-AVS4

PAGE INDEX

PACKAGE CONTENT	2
FUNCTION CONTROLS	3
SYSTEM SETUP	4
HARDWARE INSTALLATION	5
OPERATIONS.....	6
TROUBLE SHOOTING	8

PACKAGE CONTENT

The standard package of this product includes the following items:

- Wireless Transmitter Unit
- Wireless Receiver Unit
- DC Power Adapter x 2
- Infrared Remote Control Extender Wire
- Composite RCA A/V Cable x 2
- User Manual

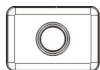

Transmitter



Receiver



Infrared Extender



RCA to RCA cable



9V Power Adaptor



Users Manual

FUNCTION CONTROLS

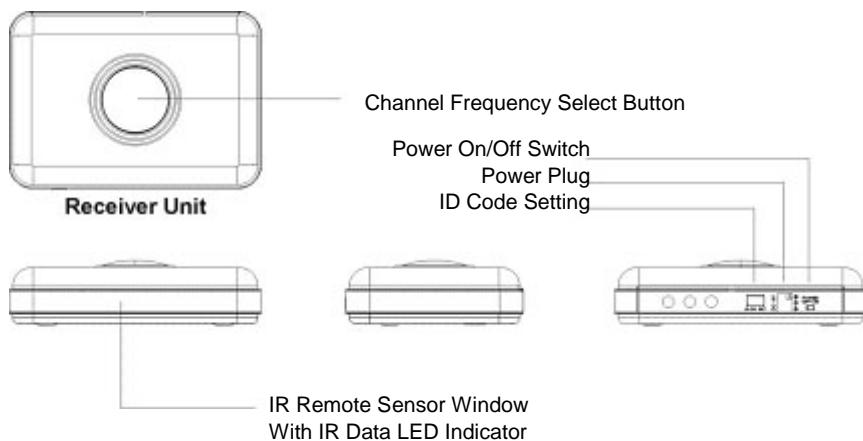
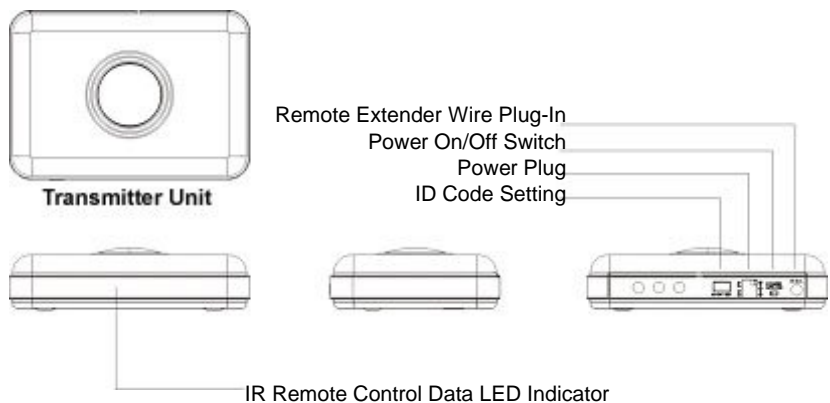

[Note]:

The 4 selectable transmission frequency channels are solely controlled from the wireless receiver end only.

SYSTEM SETUP

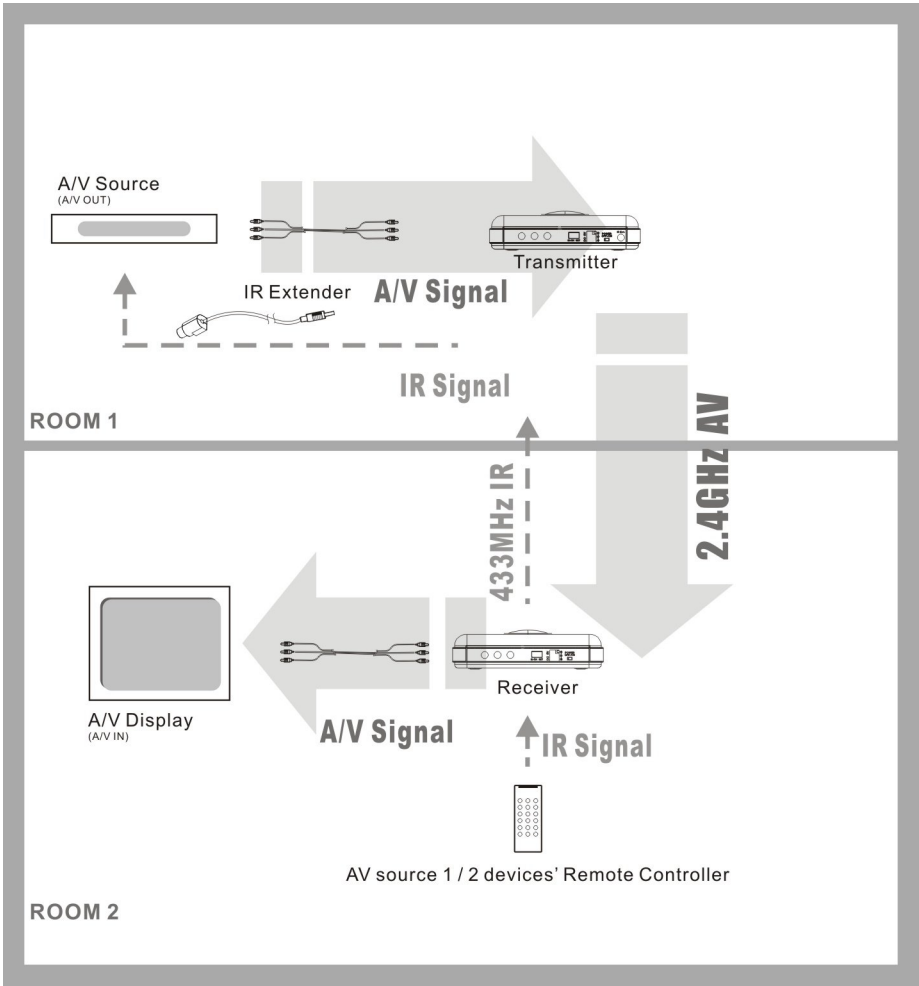

HARDWARE INSTALLATION

[For Transmitter Unit]: Connect the transmitter unit to the audio/video source device such as DVD/VCR, satellite receiver, camcorder , stereo receiver, CCTV camera, Hi-Fi System, etc.

A/V Sources



Transmitter

[For Receiver Unit]: Connect the wireless receiver to an end receiving equipment such as TV, projector, A/V receiver, video monitor, powered speaker, etc.

A/V Displays



(AV IN)

Receiver

[For Power Supply]: Connecting the supplied power adapters between the household outlets and the wireless transmitter/receiver units.



Connect to Power Jack

[For IR Extender Wire]: Plug the infrared remote control extender wire to the transmitter unit's IR port in the back panel first. Next try positioning the head of the IR extender wire in front of the A/V device's IR sensor window or attaching it onto the A/V source's IR sensor window using double-sided tape.



OPERATIONS

- Power on both transmitter and receiver unit using the supplied power adapters from the standard package.
- Connect the wireless transmitter unit to the A/V source device by using the supplied composite RCA cable and power them on thereafter.
- Connect the wireless receiver unit to the TV display or video monitor by using the supplied composite RCA cable and power them on thereafter. Make sure TV is set for displaying the right video channel input.
- Check and make sure that the ID code setting is the same on both the transmitter and receiver unit.
- Take the remote controller of the AV source device (ex. STB / DVD) to where the receiver is located.
- Try aiming your remote control toward the front panel of the receiver unit and you should see the IR Remote Data LED on the front panel of the receiver unit start to flash in red.
- At any time if you need to change the channel frequency for transmission, simply press the channel select button on the top of the receiver unit. There are 4 channels of frequencies to be selected. **[Note]:** The receiver will not function properly if you press the channel button for switching channel while the IR Data LED is flashing.

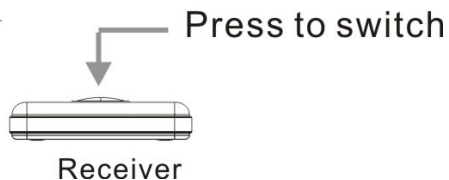
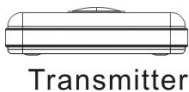

TROUBLE SHOOTING

Q1: Got No Picture or Sound After The Setup ?

--> Check the power adapters and see if the power LED on both TX and RX units are on. If not, check the connection of power adapters and make sure that the power on/ff switch in the back of TX and RX units are switched on correctly.

--> Check if all the A/V cables are known good and connected well.

--> The ID code dip switch settings from both transmitter and receiver units must be matched in the same configuration.

--> Check if the Transmitter and Receiver are set at using the same channel frequency.

2. Got Interference Experienced In The Image/Sound ?

--> Move your transmitter or receiver unit slowly to find a better reception position for your A/V system.

--> Try to have the transmitter get closer to the receiver unit.

--> Move the TX and RX units away from possible interference from microwave oven or cordless phone.

--> Try switching the channel frequency to avoid interference.

--> Check if the Transmitter and Receiver are set at using the same channel.

3. Remote Control Function Does Not Work ?

--> Check the batteries in your device's remote controller first.

--> Make sure the IR remote extender wire is facing toward the A/V device's IR window and the remote controller is aiming toward the IR sensor window located on the front panel of the Receiver unit.

--> Make sure the distances from your remote control to the receiver's IR window and from remote extender wire to the transmitter are within the valid range.

--> Check the ID code setting on both TX and RX units are the same one.

4. What The ID Code Setting Is Used For ?

This ID code setting helps users avoid the possible interference of remote controller originated from your neighborhood. For example both you and the neighbor have the same satellite receiver model with same remote and IR codes programmed. In this coincidence your neighbor's remote controller may interfere with your receiver when both of you are also using our same wireless A/V transmitter kit for remote control extension. That is why we design this ID code switch for users to avoid such an interference on the remote control when the unlikely does happen.

--> Make sure that both ID codes of transmitter and receiver are set the same positions. In most cases, you do not need to worry about this ID code setting. Default setting is recommended.

-->The ID code can be configured in 8 different types through using the dip switch on the back panel of transmitter TX unit or receiver RX unit. Again in most cases, you do not need to worry about this ID code setting. Default setting is always recommended unless change is necessary.

